

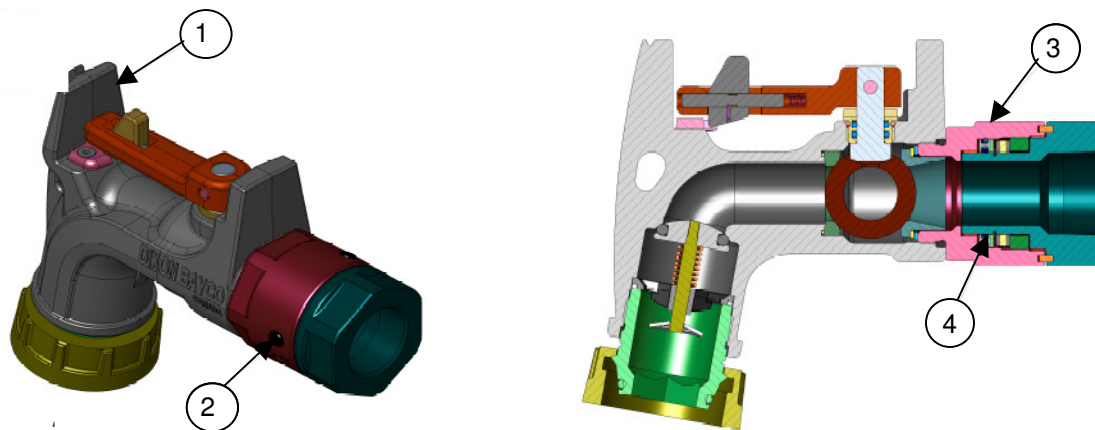

The Right Connection™

New Ball Valve Nozzle



Features:

1. New Compact Profile
2. New hose swivel design provides easy movement and leak free operation
3. New swivel seals are easy to replace and swivel can be rebuilt while still attached to the hose
4. Swivel design allows for easy re-greasing without teardown



For further information on the brake interlock or our range of tanker fittings and overfill prevention system, please contact our sales department on 01772 323529

Dixon Group Europe Ltd

350 Leach Place, Walton Summit Centre, Preston, PR5 8AS

Tel: 01772 323529 Fax: 01772 314664

www.dixoneurope.co.uk • enquiries@dixoneurope.co.uk